

Analog Metropolis

AM8075 ARP Voltage Controlled 24dB Low Pass Filter

Project Notes V1.0

© Analog Metropolis 2009
Rob Keeble
Contact: info@emulatoarchive.com
Web Site: www.emulatorarchive.com

28 February 2009

3 The Analog Metropolis Circuit

The cloned circuit is exactly the same as the original, as all the components are easy to locate. The AM module contains the original ARP module circuit as well as the additional circuitry of CV and signal summing which is held on the main ARP PCB's. This provides a self contained module for use within any modular system, rather than a replacement module for ARP synthesizers.

Transistor pairs have been used, rather than expensive pre-matched transistor pairs (e.g. SSM2210), and the filter works perfectly well without hand matching the transistors. The CV summing Op Amp is a high quality (low offset) OP177 rather than the original LM1458.

All capacitors have been upgraded as well; 1% polystyrene capacitors are used in the main filter core, WIMA and Panasonic Audio capacitors in the audio signal paths and Panasonic FC capacitors in the power supply. The trimmers are all cermet 20 turn. These upgrades pay off, the filter sounds fantastic!

The Tempco resistor can be omitted (and a standard metal film resistor used) if you are not concerned about the filter oscillation tracking properly. We have had 1K87 3500ppm Tempco resistors specially manufactured, and we recommend fitting one of them.

The frequency control circuitry of the original has been expanded to include a dedicated keyboard CV input, as well as a FINE front panel control and an internal frequency trimmer for setting up the filters response.

The REV02 board is the production board, with no errors or corrections.

4 PCB

The PCB is double sided with solder mask and silkscreen on the upper surface. The component names are shown in the silk screen but not the component values. The size of the PCB is 80mmx100mm.

The PCB is held to the front panel at 90 degrees by the use of four pot brackets manufactured by ECO. These brackets (and pots) are centred at 25.4mm apart. The FREQ, FINE, CV1 and CV2 pots will hold the PCB to the front panel if you do not wish to use pot brackets.

5 PCB Connections

The PCB has a number of connections designed for MTA 0.1" headers, so that the panel components can be connected to the PCB. I use headers and sockets to enable the board to be easily replaced, however you can solder wires straight to the PCB.

PCB Header Name	Pin #	What is it?	Where does it go?
INS	Pin 1	Input Signal A	Centre pin of SIGNALA pots
	Pin 2	Input Signal B	Centre pin of SIGNALB pots
	Pin 3	Input Signal C	Centre pin of SIGNALC pots
	Pin 4	Ground	Lower pin of SIGNALA, SIGNALB and SIGNALC pots
RESO	Pin 1	Resonance Pot	RESONANCE Pot Pin 1
	Pin 2	Resonance Pot	RESONANCE Pot Pin 2
	Pin 3	Resonance Pot	RESONANCE Pot Pin 3
CV_INS	Pin 1	CV1 In	Jack socket CV1 IN
	Pin 2	CV2 In	Jack socket CV2 IN
	Pin 3	CV In	Keyboard CV bus or optional CV
OUTPUT	Pin 1	Signal Output	Jack socket OUT
	Pin 2	Signal Output	Not Used
PAD	Pin 1	Panel Earth	Jack socket earth bus

The AM8075 has a MTA connector for 3 signal inputs but there are no individual connectors for each signal level pot (as per many other AM modules). This has been done to save PCB space and achieve a 100x80mm PCB size. The individual pots for each signal levels need to be manually wired up as shown below:

SIGNALA	Pin 1	Signal A Pot	Wire to GND (CV Pin 1)
	Pin 2	Signal A Pot	Wire to SIG_INS Pin 1
	Pin 3	Signal A Pot	Wire to SIGNALA Jack Socket
SIGNALB	Pin 1	Signal B Pot	Wire to GND (CV Pin 1)
	Pin 2	Signal B Pot	Wire to SIG_INS Pin 2
	Pin 3	Signal B Pot	Wire to SIGNALB Jack Socket
SIGNALC	Pin 1	Signal C Pot	Wire to GND (CV Pin 1)
	Pin 2	Signal C Pot	Wire to SIG_INS Pin 3
	Pin 3	Signal C Pot	Wire to SIGNALC Jack Socket

6 Pots & Power

The PCB is designed to be used with Alpha 16mm potentiometers, either round or splined shaft.



The module should be powered from a well regulated +15V and -15V power supply, current consumption is around 25mA. The power connector is the standard two ground MOTM/Oakley 4-pin Molex connector. One ground is for the circuit, the other is for the panel (PAD) or jack socket bus.

7 Parts

The filter uses 1% polystyrene capacitors, which improve the sound quality of the filter. Axial versions can be fitted vertically, but the PCB is designed for using a version manufactured by LCR Components in a radial package, the EXF/HR. These are available from Farnell.



8 Front Panel

The AM8075 is designed to be used with a standard 3" FracRac panel, although other shapes and sizes can be used. I built my module with 6 jack sockets on the left hand side, the PCB mounted in the middle with the on board pots and then the off board pots for the signal levels and resonance on the right.

8 Building the Module

This module is simple to build. The recommended build order is:

- Resistors
- Inductors
- IC Sockets
- Capacitors
- Trimmers
- Connectors
- Transistors
- Pot Brackets and Potentiometers

Check all the electrolytic capacitors and transistors are fitted the right way round. Before fitting the IC's its worth connecting up the module to a power supply and checking that the power rail voltages are as expected at each IC socket, then power down, and fit the IC's ensuring correct orientation.

Power up and try out the filter. Then proceed to trimming. Watch out for the speaker shredding resonance.

10 Trimming

This module has three trimmers which need to be adjusted for accurate operation of the filter.

TRIM This trimmer adjusts the initial cut-off frequency of the filter. Set the **FREQ** and **FINE** pots to minimum and turn **RESO (Q)** up so that the filter begins to oscillate. Monitor the filter output with an oscilloscope or frequency counter and adjust **FC_TRIM** for a 62.5ms period or 16Hz.

REJECT This trimmer adjusts the filter for minimum CV bleed through. Listen to the audio output whilst patching an **ADSR** into the **CV1** input. Adjust the trimmer for minimal output whilst repeatedly triggering the **ADSR**.

V/OCT This trimmer adjusts the CV input response, so that the filter accurately tracks the keyboard and oscillators. Turn **RESO (Q)** so that the filter begins to oscillate. Patch the keyboard CV into the **CV1** socket on the PCB. Press **C4** on the keyboard and adjust the **FREQ** control so that turning **V/OCT** trimmer has minimal effect. Tune a reference oscillator so that it zero-beats with the note appearing at the Band Pass output. Be sure the reference oscillator is not controlled by the keyboard. Now, press **C5** on the keyboard and trim **V/OCT** so the note from the filter zero-beats with the reference oscillator. Repeat as necessary.

11 Special Components

The AM8075 makes use of a small number of specialist components:

Tempco Resistor

The 1K87 3500ppm/°C Tempco can be obtained from Precision Resistors, they have UK and USA distribution. You need the PT146 resistor, and they may ask for a minimum order of 5 or 10 items.

<http://www.precisionresistor.com/>

A 1K87 1% resistor can be used if you aren't concerned about the filter tracking the keyboard when it is self-oscillating.

Pot Brackets

ECO pot brackets can be obtained from Omeg in the UK.

<http://www.omeg.co.uk/>

12 Parts Listing

Part Number	Value	#	Comments
Capacitors			
C1, C7, C18, C19	100nF	4	Multi-layer Polyester
C2, C17	47nF	2	Multi-layer Polyester
C3, C4	10nF	2	Multi-layer Polyester
C5, C6, C11, C12	4700pF	4	1% Polystyrene
C8, C9	22uF 25V	2	Radial Electrolytic
C10	220pF	1	Low-K Ceramic
C13, C14, C15, C16	10uF 25V	4	Radial Electrolytic
Resistors			
All 1/4W 1% metal resistors			
R1, R2, R3	360K	3	
R4, R5, R7, R8	100K	4	
R6	1K	1	
R9, R15	470K	2	
R10	1M5	1	
R11	150K	1	
R12	91K	1	
R13	196K	1	
R14	22K	1	
R16	39K	1	
R17	56K	1	
R18, R19	3K3	2	
R20, R22, R26, R28, R32, R34, R38, R40	220R	8	
R21, R39	2K2	2	
R23, R24, R29, R30, R35, R36, R41	12K1	7	
R25, R31, R37, R42, R44	22M	5	or 5% carbon
R27, R33	2K2	2	
R43, R45	15K	2	
R46	4K7	1	
R47, R48, R49	10K	3	
PTC1	1K87	1	3500ppm 1% Tempco
Potentiometers			
CV1, CV2, FREQ, RESO, FINE	100K LIN	5	Alpha 16mm PCB mount
SIGNALA, SIGNALB, SIGNALC	100K LOG	3	Alpha 16mm PCB mount
REJECT	100R	1	Ceramic Multi-turn
TRIM	100K	1	Top Adjust
V/OCT	20K	1	e.g. Murata PV36W series
Semiconductors			
IC1	OP177GP	1	Single Op Amp
IC2	LM3900	1	OTA
T1,T2,T13,T14,T15	2N3906	5	PNP Transistor
T3,T4,T5,T6,T7,T8,T9,T10,T11,T12	2N5087	10	Matched PNP Transistors Unmatched works fine!
T16	2N3904	1	NPN Transistor
D1	1N914	1	Diode
Passives			
L1, L2		2	Inductor
Hardware			
CV_INS, OUTPUT		2	MTA 0.1" 2-pin header
SIG_INS		1	MTA 0.1" 3-pin header
POWER		1	MTA 0.156" 4-pin header

AM8075 Module – ARP Voltage Controlled 24dB Low Pass Filter

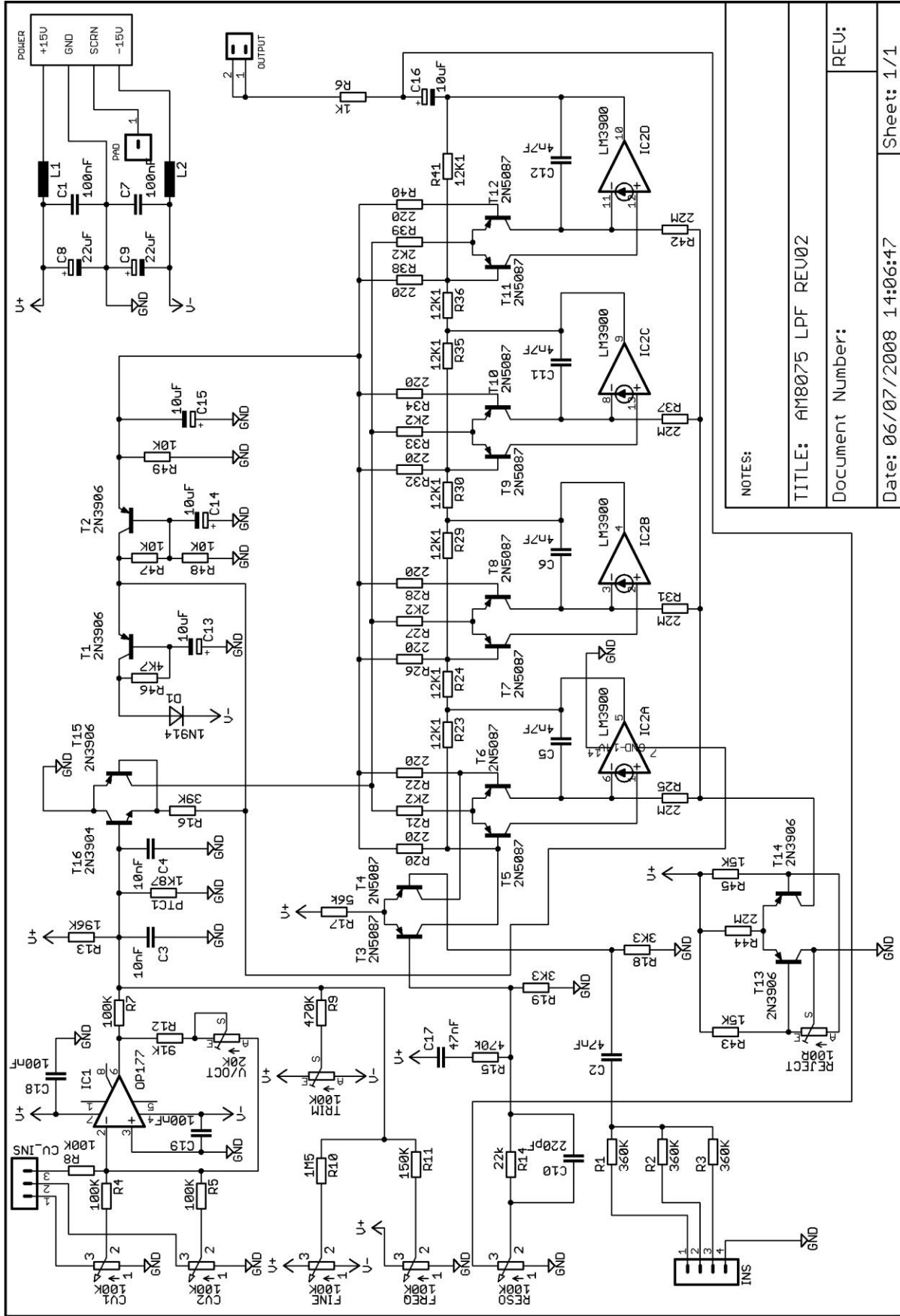

NOTES:
TITLE: AM8075 LPF REV02
Document Number:
Date: 06/07/2008 14:06:47
Sheet: 1/1